

\$1.50**THE ANIMAL RACING ENGINE**

Illustrated Parts List

Motorsports

Model Series

**124332**TYPE NUMBER
8002.**WARNING:**

- **MODEL 124332-8002-01 IS A RACING ENGINE**
- **SPECIAL SKILLS AND KNOWLEDGE ARE REQUIRED TO PREPARE THE ENGINES FOR COMPETITIVE USE. IF YOU ARE NOT FAMILIAR WITH THE PROPER TECHNIQUES AND PROCEDURES, HAVE QUALIFIED INDIVIDUALS DO THE WORK FOR YOU**
- **THE ENGINES DO NOT HAVE GOVERNORS. ANY THROTTLE MECHANISM MUST HAVE A RETURN-TO-IDLE SPRING SO THE ENGINE WILL RETURN TO IDLE SPEED WHEN THE THROTTLE PEDAL IS RELEASED**

**FAILURE TO FOLLOW THESE WARNINGS COULD
RESULT IN SERIOUS PERSONAL INJURY OR DEATH**

**TO FIND
THE CORRECT NUMBER OF THE PART YOU NEED:
FOLLOW THE INSTRUCTIONS ON THE REVERSE SIDE**

- A. Refer to Engine Model, Type and Code Number that is stamped on the blower housing of engine. Engine type numbers such as 0123 01 are listed only as 0123 in most instances. The two digits (01 or 02, etc.) to the right of the space may be required for more accurate parts identification in some instances. Select the Illustrated Parts List covering the correct Model Series and Type Number.
- B. Refer to the Illustrations and compare the original part with Illustration. The number next to the illustration is the Reference Number. Assemblies include all parts shown in frames. All parts shown in assembly frames having individual reference numbers can be purchased separately.
- C. After the Reference Number has been identified, refer to the Numerical text, where Reference and Primary Part Number are listed. **THE PRIMARY PART IS USED ON ALL TYPE NUMBERS EXCEPT THOSE TYPE NUMBERS UNDER "NOTE."**
- D. If a "Note" appears below the Primary Part Number, it means that this part differs from the Primary Part for certain types. If your Type number is listed under "Note," order the part referred to at the "Note."
- E. If your Engine Type Number does not appear after any part number listed under "Note," use the Primary Part Number.
- F. For Engine Type Numbers not covered by this book, check other Parts Lists having the same engine model or contact your source of supply.

PRINTED IN U.S.A.

BRIGGS & STRATTON

COPYRIGHT by BRIGGS & STRATTON CORPORATION
All rights reserved. No part of this material may be reproduced or transmitted, in any form or by any means, electronic or mechanical, including photocopying, recording or by any information storage and retrieval system, without permission in writing from Briggs & Stratton Corporation.

In the Interest of Safety



This safety alert symbol indicates that this message involves personal safety. The words “danger”, “warning” and “caution” indicate degree of hazard. Death, personal injury and/or property damage may occur unless instructions are followed carefully.



You are not ready to operate this engine if you have not read and understood the following safety items. Read the entire owner's manual and the operating instructions of the equipment this engine powers.

The Briggs & Stratton engine is made of the finest material in a state-of-the-art manufacturing facility. Please understand that Briggs & Stratton sells engines to original equipment manufacturers. It also sells to others in the distribution chain who may sell to the ultimate consumer, an equipment manufacturer, another distributor or a dealer. As a result, Briggs & Stratton does not necessarily know the application on which the engine will be placed. For that reason, carefully read and understand the operating instructions of the equipment before you repair or operate it.

You should also understand that there are equipment applications for which Briggs & Stratton does not approve the use of its engines. Briggs & Stratton engines are not to be used on vehicles with less than 4 wheels. They include motor bikes, aircraft products and All Terrain Vehicles. Moreover, Briggs & Stratton does not approve of its engines being used in competitive events. FOR THAT REASON, BRIGGS & STRATTON ENGINES ARE NOT AUTHORIZED FOR ANY OF THESE APPLICATIONS. Failure to follow this warning could result in death, serious injury (including paralysis) or property damage.



DO NOT run engine in an enclosed area. (Exhaust gases contain carbon monoxide, an odorless and deadly poison.)

DO NOT remove fuel tank cap nor fill fuel tank while engine is hot or running. DO NOT refuel indoors or in an unventilated area. (Allow engine to cool 2 minutes before refueling.)

DO NOT place hands or feet near moving or rotating parts.

DO NOT store, spill, or use gasoline near an open flame, nor near an appliance like a stove, furnace, or water heater that uses a pilot light or can create a spark.

DO NOT refuel indoors or in an unventilated area.

DO NOT operate or tip engine/equipment at such a severe angle that causes gasoline spillage.

DO NOT operate engine if gasoline is spilled or when smell of gasoline is present or other explosive conditions exist. (Move equipment away from spill and avoid any ignition until gasoline has evaporated.)

DO NOT transport engine with fuel in tank or fuel shut-off valve open.

DO NOT choke carburetor to stop engine, especially in an enclosed vehicle. (Whenever possible, gradually reduce engine speed before stopping.)

DO NOT tamper with governor springs, links or other parts to increase engine speed. (Run engine at speed set for equipment manufacturer.)

DO NOT check for spark with spark plug removed. (Use an approved tester.)

DO NOT run engine without blower housing or other safety shields removed when doing repairs.

DO NOT crank engine with spark plug removed. (If engine is flooded, place throttle in FAST and crank until engine starts.)

DO NOT strike flywheel with a hammer or hard object as this may cause flywheel to shatter in operation. (To remove flywheel, use Briggs & Stratton approved tools and procedures only.)

DO NOT operate engine without a muffler. (Inspect periodically and replace if worn or leaking. If engine is equipped with muffler deflector, inspect periodically and replace if necessary. Replacement parts must be same as on original equipment.)

DO NOT operate engine with an accumulation of grass, leaves or other combustible material in muffler area.

DO NOT use this engine on any forest covered, brush covered, or grass covered unimproved land unless a spark arrester is installed on muffler. The spark arrester must be maintained in working order by the owner and/or operator. In the State of California the above is required by law (Section 4442 of the California Public Resources Code). Other states may have similar laws. Federal laws apply on federal lands.

DO NOT touch hot muffler, cylinder, or fins which can cause burns.

DO NOT start engine with air cleaner or air cleaner cover removed (or cover over carburetor air intake, if Sno/Gard engine).

DO NOT attempt to start engine with cutting blade loose or removed. (Blade must be tight, otherwise a kickback may occur.)



- ✓ Prior to work, read and understand the section(s) of this manual that pertain to the job. Follow all safety warnings.
- ✓ PULL starter cord slowly until resistance is felt. Then pull cord rapidly to avoid kickback and prevent hand or arm injury.
- ✓ WEAR suitable eye protection (safety glasses, goggles or face shield when performing repair procedures.
- ✓ PREVENT ACCIDENTAL STARTING by removing spark plug wire from spark plug when servicing engine or equipment. Disconnect negative wire from battery terminal if equipped with electric starting system.
- ✓ REMOVE blower housing periodically and clean engine. Keep cylinder fins and governor parts free of dirt, grass and other debris which can affect engine speed.
- ✓ USE fresh gasoline. Stale fuel can gum carburetor and cause leakage.
- ✓ CHECK fuel lines and fittings frequently for cracks or leaks. Replace if necessary.
- ✓ USE ONLY Genuine Briggs & Stratton Parts or their equivalent. The use of replacement parts which are not of equivalent quality may damage the engine.



WARNING:



The engine exhaust from this product contains chemicals known to the State of California to cause cancer, birth defects, or other reproductive harm.

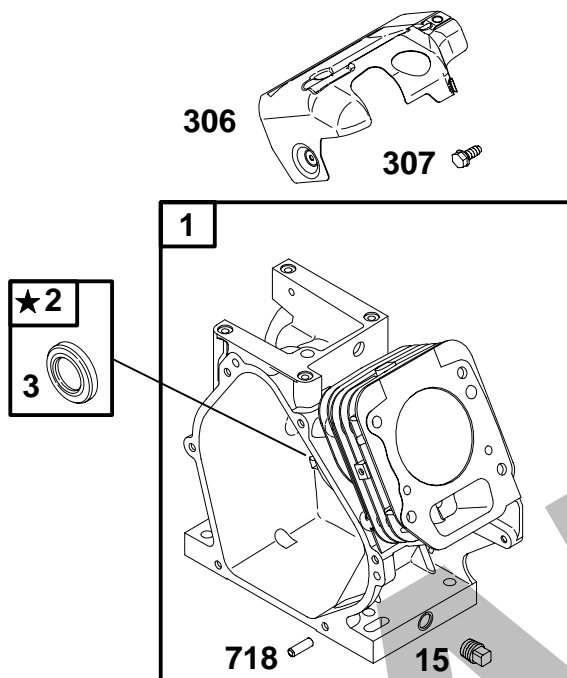

★ REQUIRES SPECIAL TOOLS TO INSTALL. SEE REPAIR INSTRUCTION MANUAL.

1019 LABEL KIT

REF. NO.	PART NO.	DESCRIPTION	REF. NO.	PART NO.	DESCRIPTION	REF. NO.	PART NO.	DESCRIPTION
1	555633	Cylinder Assembly	3	★555071	Seal-Oil (Magneto Side)	307	699483	Screw (Cylinder Shield)
2	555140	Kit-Bushing/Seal (Magneto Side)	15	555583	Plug-Oil Drain	718	555579	Pin-Locating
			306	555519	Shield-Cylinder	1019	555577	Kit-Label

★ Included in Engine Gasket Set-Ref No. 358.

● Included in Carburetor Overhaul Kit-Ref No. 121.

△ Included in Valve Gasket Set-Ref No. 1095.

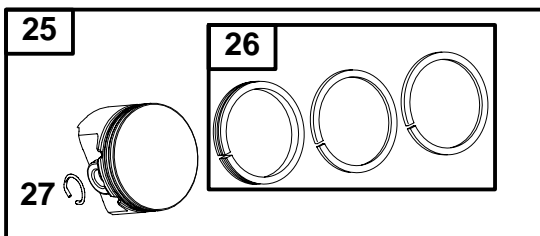
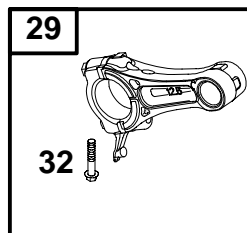
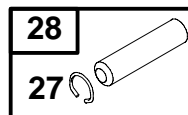

REF. NO.	PART NO.	DESCRIPTION	REF. NO.	PART NO.	DESCRIPTION	REF. NO.	PART NO.	DESCRIPTION
25	555510	Piston Assembly (Standard)	26	555514	Ring Set (Standard)	27	555521	Lock-Piston Pin
		Note			Note	28	555520	Pin-Piston
		555511 Piston Assembly (.010" Oversize)			555515 Ring Set (.010" Oversize)	29	555626	Rod-Connecting
		555512 Piston Assembly (.020" Oversize)			555516 Ring Set (.020" Oversize)	32	555070	Screw (Connecting Rod)
		555513 Piston Assembly (.030" Oversize)			555517 Ring Set (.030" Oversize)			

★ Included in Engine Gasket Set-Ref No. 358.
 Δ Included in Valve Gasket Set-Ref No. 1095.

● Included in Carburetor Overhaul Kit-Ref No. 121.

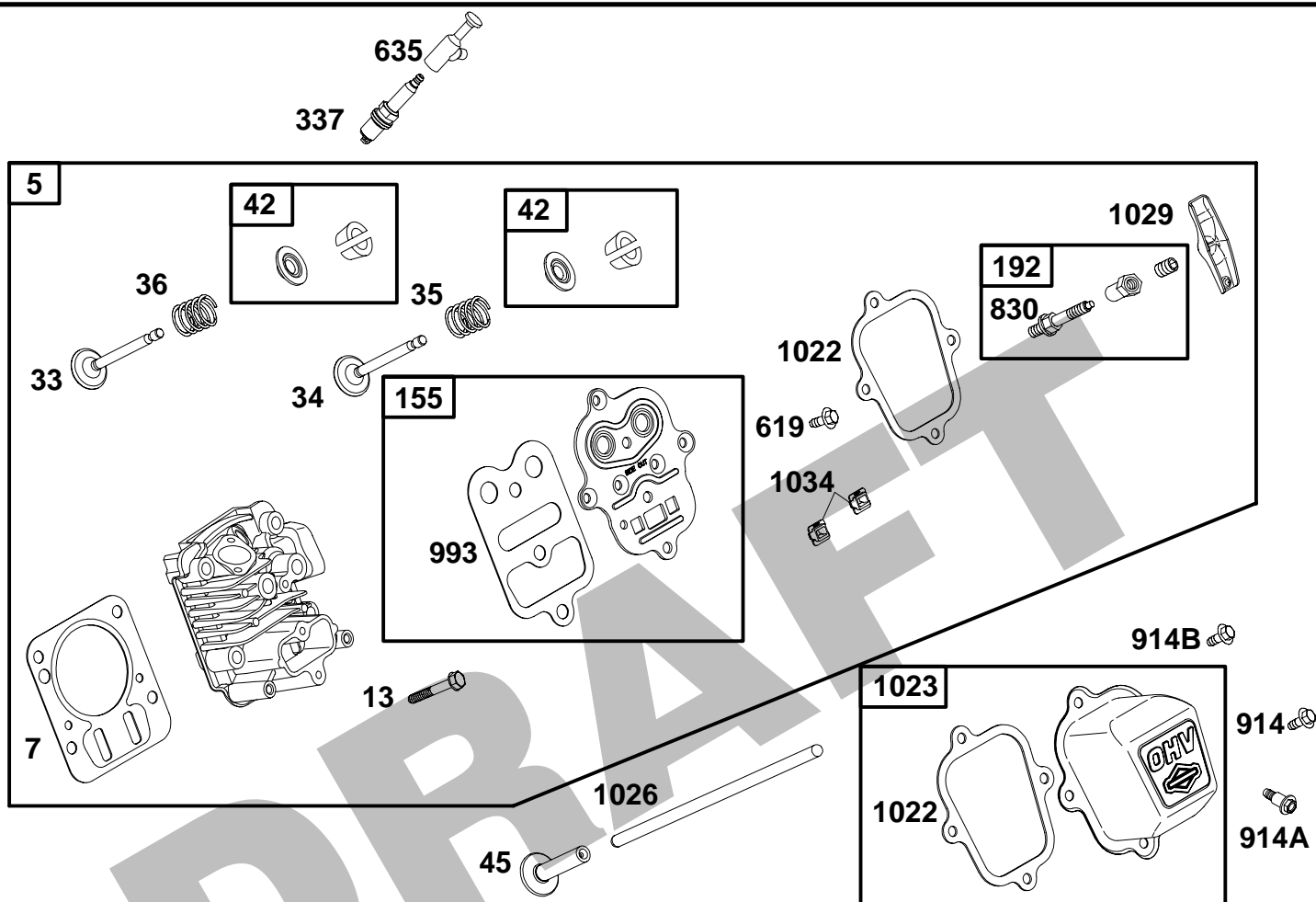

REF. NO.	PART NO.	DESCRIPTION	REF. NO.	PART NO.	DESCRIPTION	REF. NO.	PART NO.	DESCRIPTION
5	555635	Head-Cylinder	42	555550	Keeper-Valve	914	699481	Screw (Rocker Cover) (Bottom)
7	★555621	Gasket-Cylinder Head	45	555307	Tappet-Valve	914A	555542	Screw (Rocker Cover) (Top)
13	699482	Screw (Cylinder Head)	155	555547	Plate-Cylinder Head	914B	555614	Screw (Rocker Cover) (Center)
33	555552	Valve-Exhaust	192	555548	Adjuster-Rocker Arm	993	★△555554	Gasket-Cylinder Head Plate
34	555551	Valve-Intake	337	491055	Plug-Spark	1022	★△555523	Gasket-Rocker Cover
35	555553	Spring-Valve (Intake)	619	699230	Screw (Cylinder Head Plate)	1023	555528	Cover-Rocker
36	555553	Spring-Valve (Exhaust)	635	555162	Boot-Spark Plug	1026	555531	Rod-Push
			830	555549	Stud (Rocker Arm)	1029	555546	Arm-Rocker
						1034	555555	Guide-Push Rod

★ Included in Engine Gasket Set-Ref No. 358.
 △ Included in Valve Gasket Set-Ref No. 1095.

● Included in Carburetor Overhaul Kit-Ref No. 121.

24 

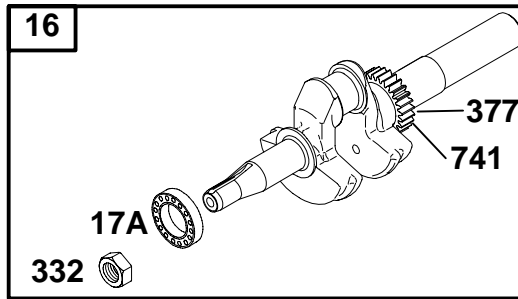

REF. NO.	PART NO.	DESCRIPTION	REF. NO.	PART NO.	DESCRIPTION	REF. NO.	PART NO.	DESCRIPTION
16	555622	Crankshaft	332	699359	Nut (Flywheel)	377	555049	Key-Woodruff
17A	555573	Bearing-Ball				741	555574	Gear-Timing
24	555054	Key-Flywheel						

DRAFT

★ Included in Engine Gasket Set-Ref No. 358.
 Δ Included in Valve Gasket Set-Ref No. 1095.

● Included in Carburetor Overhaul Kit-Ref No. 121.

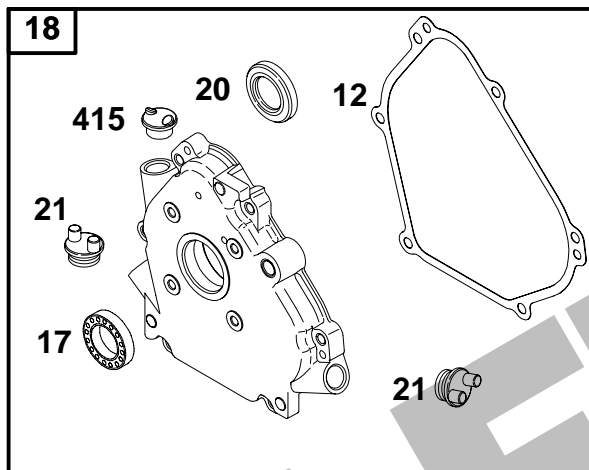

REF. NO.	PART NO.	DESCRIPTION	REF. NO.	PART NO.	DESCRIPTION	REF. NO.	PART NO.	DESCRIPTION
12	★699485	Gasket-Crankcase	20	★555529	Seal-Oil (PTO Side)	22	699478	Screw (Crankcase Cover/Sump)
17	555527	Bearing-Ball	21	555037	Cap-Oil Fill	415	555563	Plug
18	555630	Cover-Crankcase						

★ Included in Engine Gasket Set-Ref No. 358.
 Δ Included in Valve Gasket Set-Ref No. 1095.

● Included in Carburetor Overhaul Kit-Ref No. 121.

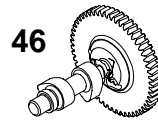

REF. NO.	PART NO.	DESCRIPTION	REF. NO.	PART NO.	DESCRIPTION	REF. NO.	PART NO.	DESCRIPTION
46	555532	Camshaft (Machined) Note 555584 Camshaft (Unmachined)						

★ Included in Engine Gasket Set—Ref No. 358.
 △ Included in Valve Gasket Set—Ref No. 1095.

● Included in Carburetor Overhaul Kit—Ref No. 121.

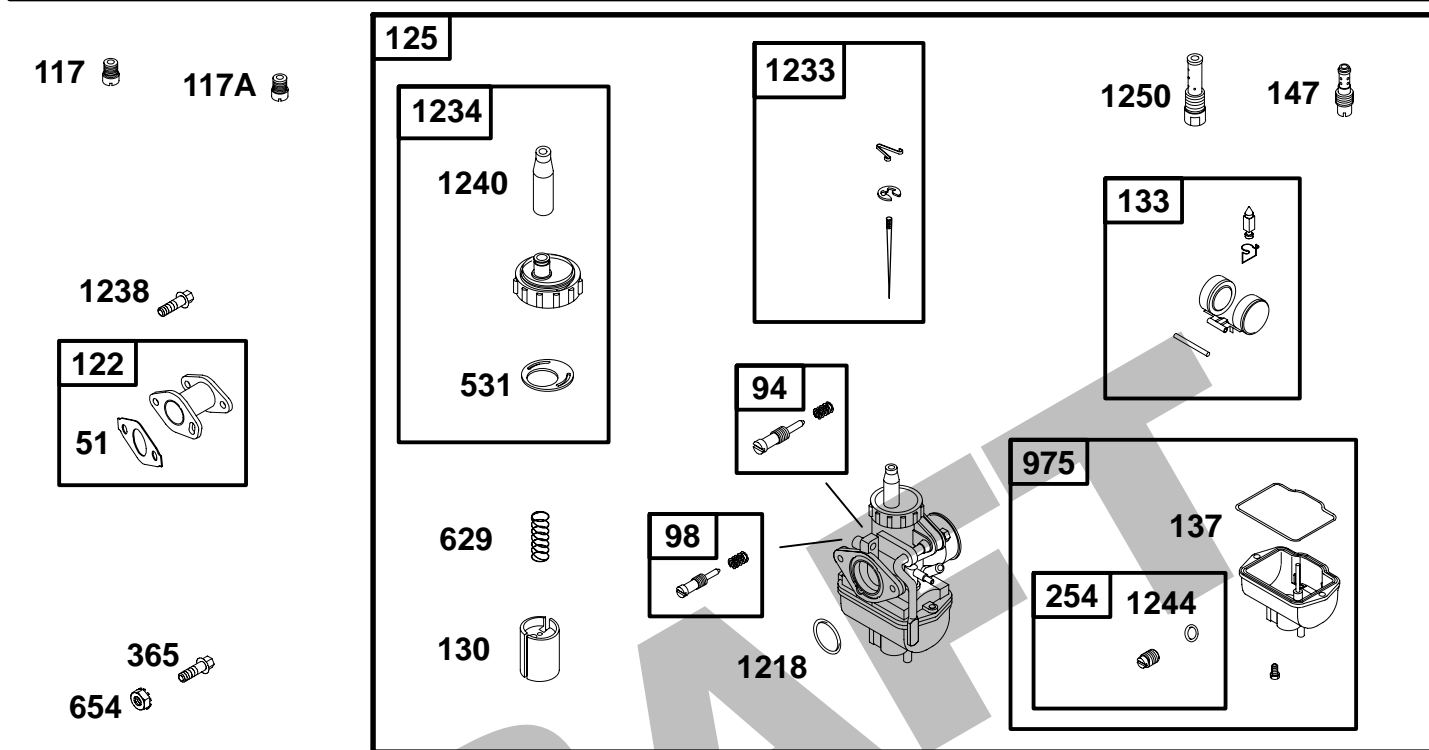

REF. NO.	PART NO.	DESCRIPTION	REF. NO.	PART NO.	DESCRIPTION	REF. NO.	PART NO.	DESCRIPTION
	51	★ 555609 Gasket-Intake		133	555591 Float-Carburetor		975	555598 Bowl-Float
	94	555585 Kit-Idle Mixture		137	●555592 Gasket-Float Bowl		1218	●555601 Seal-O Ring (Carburetor)
	98	555586 Kit-Idle Speed		147	555594 Jet-Pilot		1233	555602 Jet-Needle
	117	555536 Jet-Main (Gasoline) (Contains 7 Different Sizes)		254	555607 Drain-Carburetor Bowl		1234	555603 Cap-Throttle Cable
	117A	555537 Jet-Main (Alcohol) (Contains 8 Different Sizes)		365	555544 Screw (Carburetor) (Carburetor to Spacer)		1238	555628 Screw (Carburetor Spacer) (Spacer to Cylinder)
	122	555545 Spacer-Carburetor		531	●555595 Gasket-Throttle Cable Cap		1240	● Boot-Throttle Cable (Sold In Kit Only)
	125	555560 Carburetor		629	555596 Spring-Throttle Return		1244	● Seal-O Ring (Sold In Kit Only)
	130	555590 Valve-Throttle		654	555541 Nut (Carburetor)		1250	555593 Tube-Emulsion

★ Included in Engine Gasket Set-Ref No. 358.
 Δ Included in Valve Gasket Set-Ref No. 1095.

● Included in Carburetor Overhaul Kit-Ref No. 121.

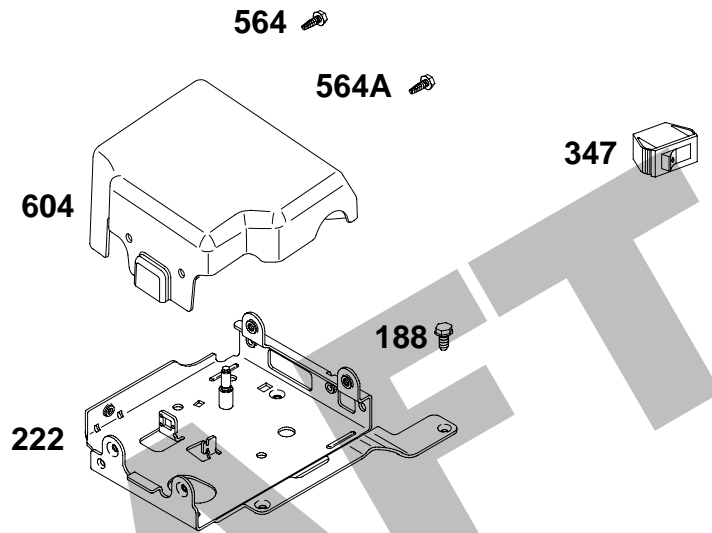

REF. NO.	PART NO.	DESCRIPTION	REF. NO.	PART NO.	DESCRIPTION	REF. NO.	PART NO.	DESCRIPTION
188	699479	Screw (Control Bracket)	564	699491	Screw (Control Cover)	604	555613	Cover-Control
222	699493	Bracket-Control	564A	699492	Screw (Control Cover)			
347	555564	Switch-Rocker						

★ Included in Engine Gasket Set-Ref No. 358.
 Δ Included in Valve Gasket Set-Ref No. 1095.

● Included in Carburetor Overhaul Kit-Ref No. 121.

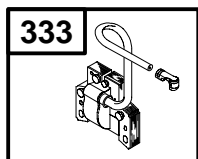

334 

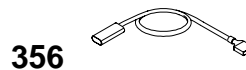

REF. NO.	PART NO.	DESCRIPTION	REF. NO.	PART NO.	DESCRIPTION	REF. NO.	PART NO.	DESCRIPTION
333	557040	Armature-Magneto	334	699477	Screw (Magneto Armature)	356	555569	Wire-Stop
						356A	555568	Wire-Stop

★ Included in Engine Gasket Set-Ref No. 358.
 Δ Included in Valve Gasket Set-Ref No. 1095.

● Included in Carburetor Overhaul Kit-Ref No. 121.

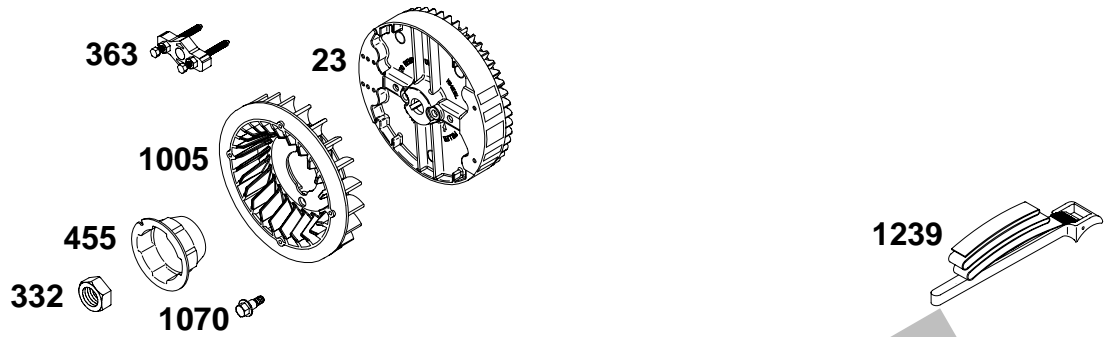

REF. NO.	PART NO.	DESCRIPTION	REF. NO.	PART NO.	DESCRIPTION	REF. NO.	PART NO.	DESCRIPTION
23	555625	Flywheel	363	19069	Puller-Flywheel	1070	699201	Screw
332	699359	Nut (Flywheel)	455	555518	Cup-Flywheel	1239	19433	Wrench-Flywheel
			1005	555526	Fan-Flywheel			

★ Included in Engine Gasket Set-Ref No. 358.
 △ Included in Valve Gasket Set-Ref No. 1095.

● Included in Carburetor Overhaul Kit-Ref No. 121.

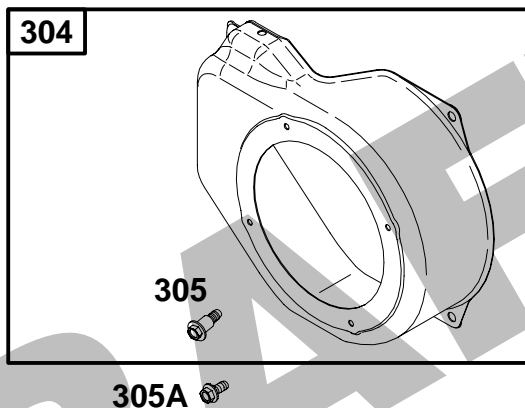

REF. NO.	PART NO.	DESCRIPTION	REF. NO.	PART NO.	DESCRIPTION	REF. NO.	PART NO.	DESCRIPTION
304	555623	Housing-Blower	305	555629	Screw (Blower Housing)			
			305A	557042	Screw (Blower Housing)			

★ Included in Engine Gasket Set-Ref No. 358.
 △ Included in Valve Gasket Set-Ref No. 1095.

● Included in Carburetor Overhaul Kit-Ref No. 121.

124332

608

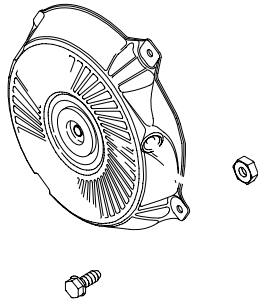

REF. NO.	PART NO.	DESCRIPTION	REF. NO.	PART NO.	DESCRIPTION	REF. NO.	PART NO.	DESCRIPTION
608	555576	Starter-Rewind						

DRAFT

★ Included in Engine Gasket Set-Ref No. 358.
 △ Included in Valve Gasket Set-Ref No. 1095.

● Included in Carburetor Overhaul Kit-Ref No. 121.

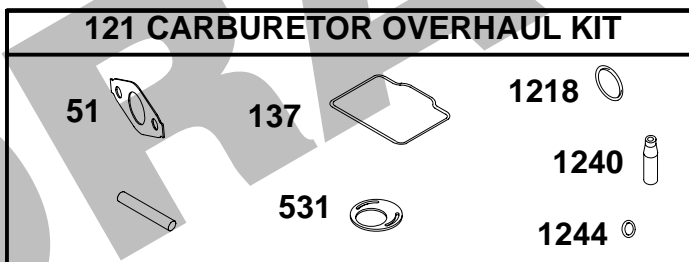
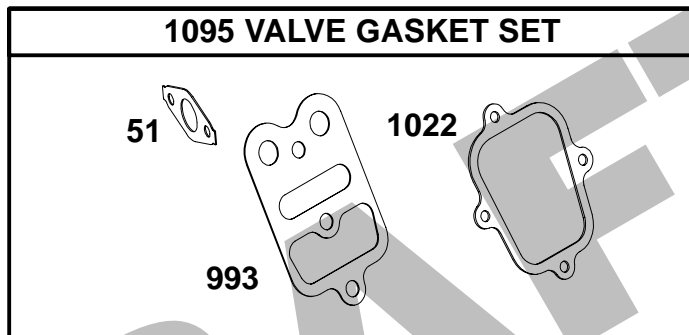
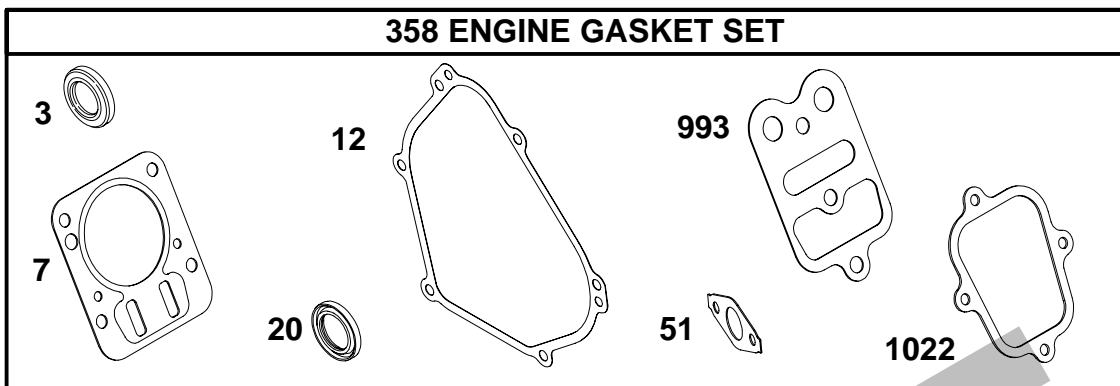

REF. NO.	PART NO.	DESCRIPTION	REF. NO.	PART NO.	DESCRIPTION	REF. NO.	PART NO.	DESCRIPTION
3	★555071	Seal-Oil (Magneto Side)	121	555605	Kit-Carburetor Overhaul	993	★Δ555554	Gasket-Cylinder Head Plate
7	★555621	Gasket-Cylinder Head	137	●555592	Gasket-Float Bowl	1022	★Δ555523	Gasket-Rocker Cover
12	★699485	Gasket-Crankcase	358	555631	Gasket Set-Engine	1095	555581	Gasket Set-Valve
20	★555529	Seal-Oil (PTO Side)	531	●555595	Gasket-Throttle Cable Cap	1218	●555601	Seal-O Ring (Carburetor)
51	★Δ555609	Gasket-Intake				1240		● Boot-Throttle Cable (Sold In Kit Only)
						1244		● Seal-O Ring (Sold In Kit Only)

★ Included in Engine Gasket Set-Ref No. 358.
 Δ Included in Valve Gasket Set-Ref No. 1095.

● Included in Carburetor Overhaul Kit-Ref No. 121.